

TNK – Complete Tank Solutions
Air Release Optimized filtration in a turn-key solution with cleanliness insured



FAST Fifteen

Give us 15 - we will give you targeted fluid cleanliness concepts for your machine.

Portfolio Need/Applications for TNK

- Ideal for small to medium OEM's that do not have enough machine volume to justify the tooling cost on their own.
- The TNK family has numerous options for a variety of application needs
- Complete filter options with each tank package
- Certified Clean to SI Specifications.
- Available with Quality Protected Elements

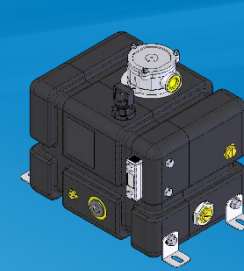

TNK7

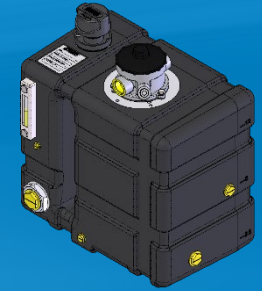

TNK12

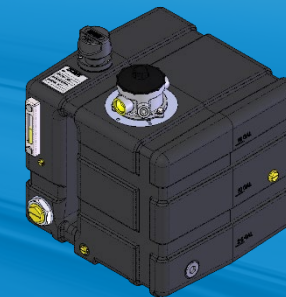

TNK18

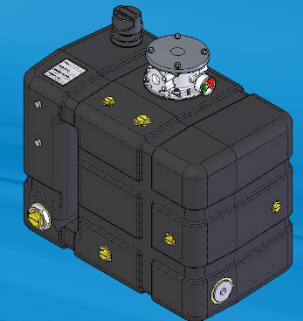

TNK25



Competitive Advantage of TNK

- No Tooling Charges
- Readily Available
- Single Purchased Order
- Weight Reduction
- Tank Cleanliness
- No Assembly Labor Cost



TNK Design Considerations

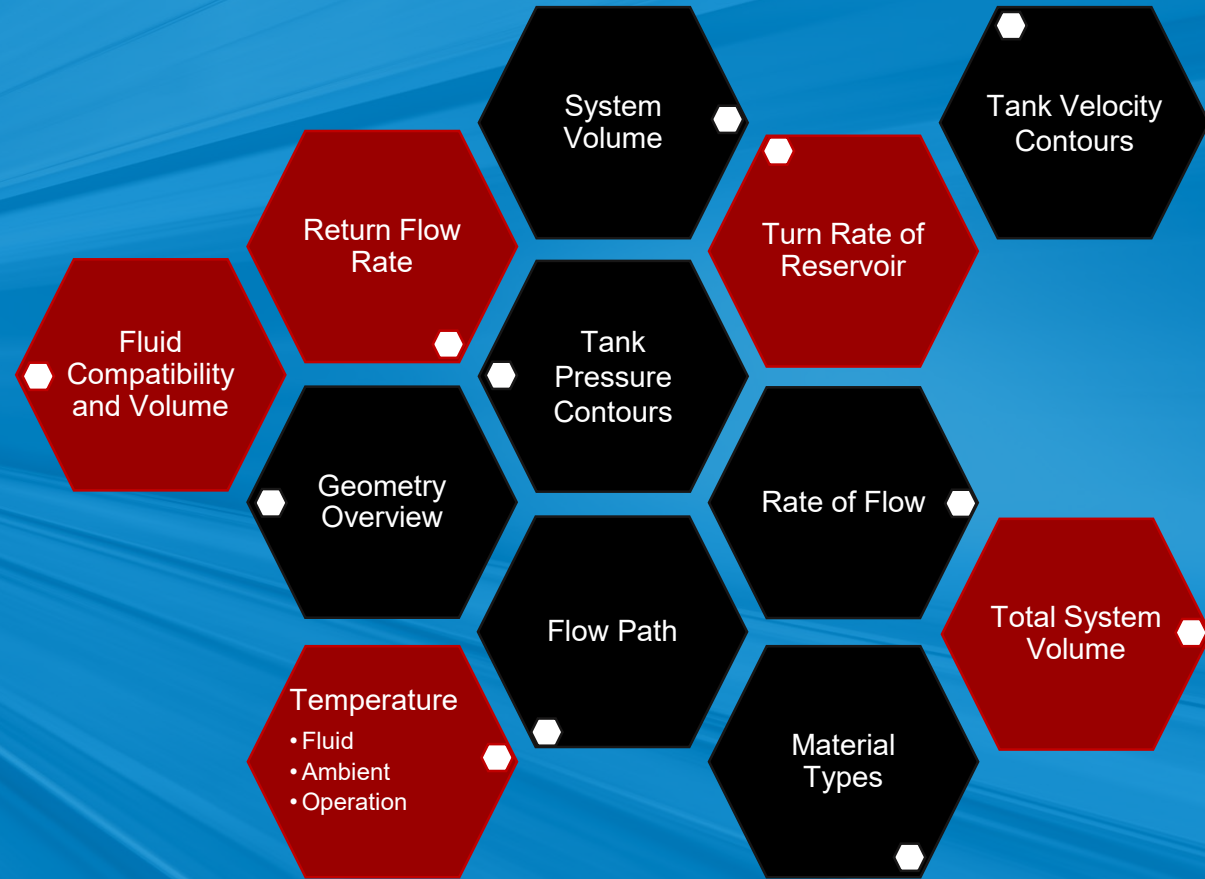
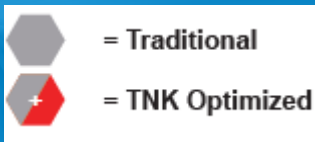

Optimization Opportunity Showcase

- Currently Use a 15 gallon tank off the shelf with in line filter. Not a package.
-
- Bulk Commodity trailer application with a low duty cycle.
- 35 GPM
- 140 deg. °F
- ISO 32 Oil



Schroeder
INDUSTRIES



Full Flow Streamlines with Diffuser

There is a large outward flow towards the walls where the flow is funneled and redirected to the outlet:

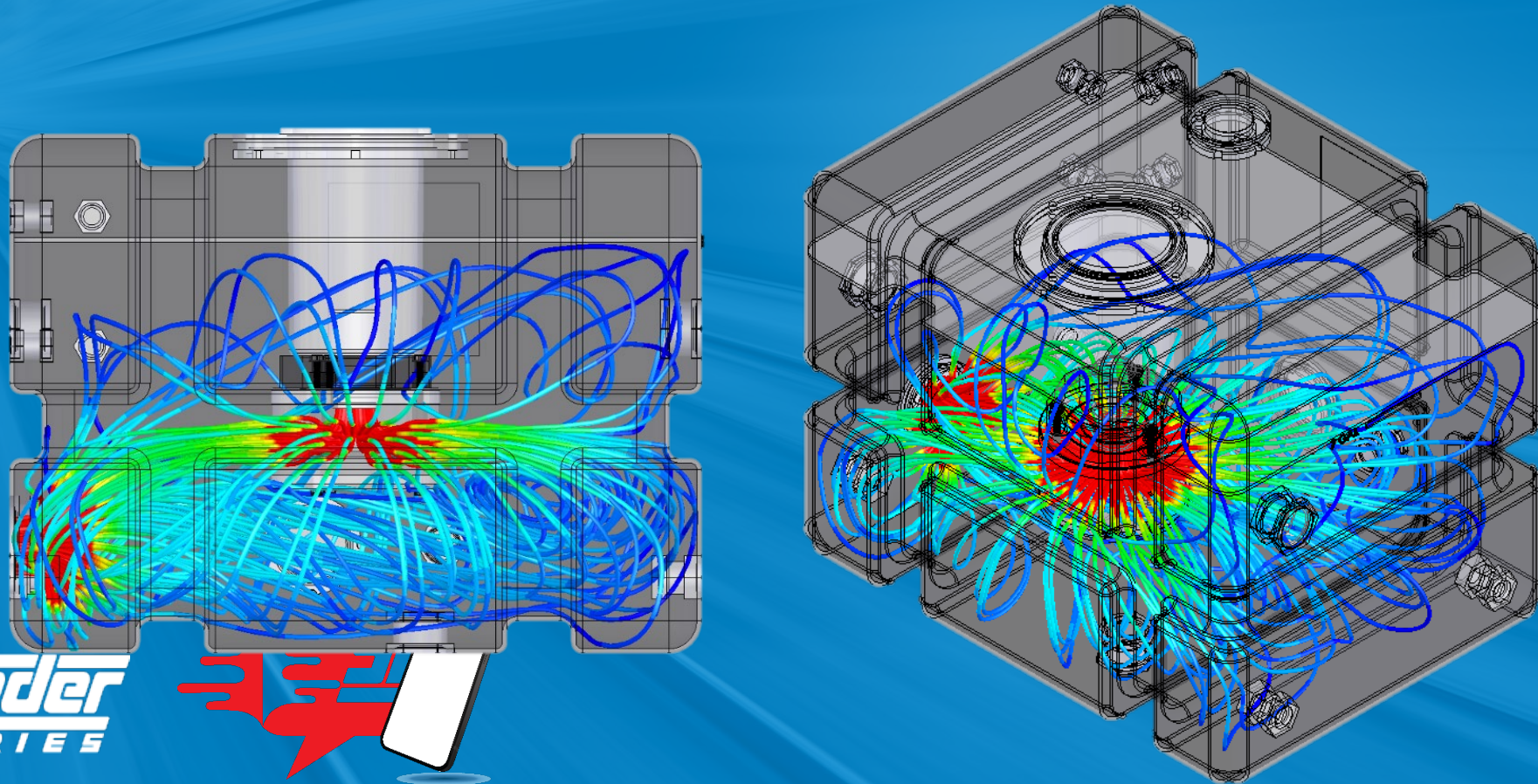

Surface Velocities with Diffuser

Surface Velocities are well within acceptable limits (< 0.8 m/sec)

Velocity Contours

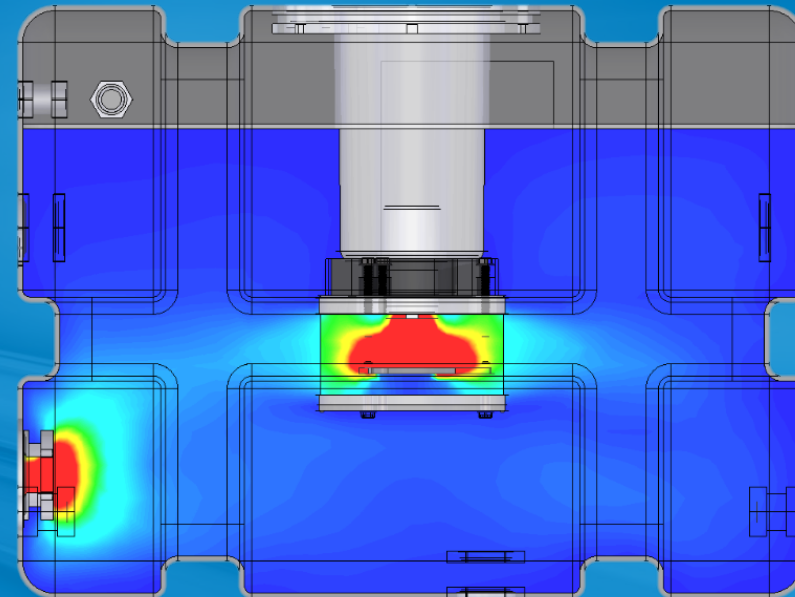
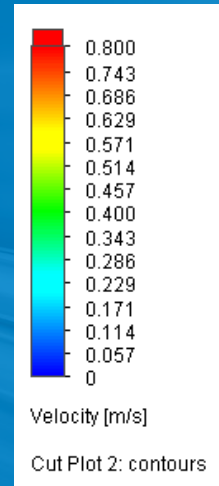
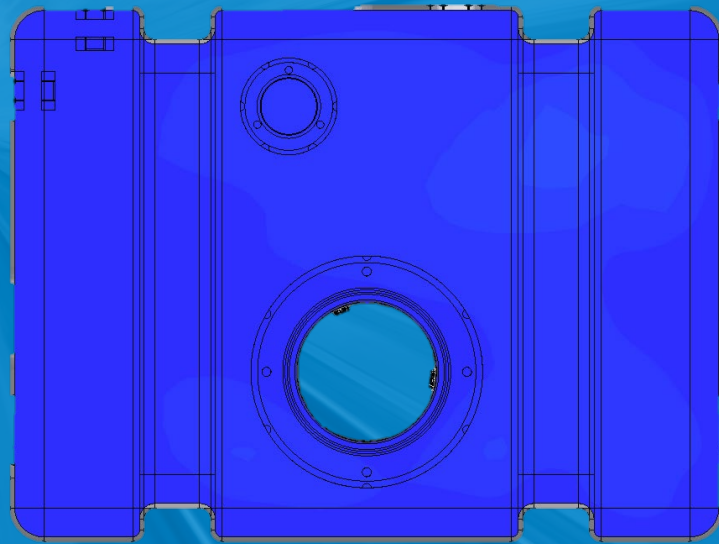

De-aeration Performance with Diffuser

Values shown are the percent of air bubbles at that particular size successfully de-aerated from the system

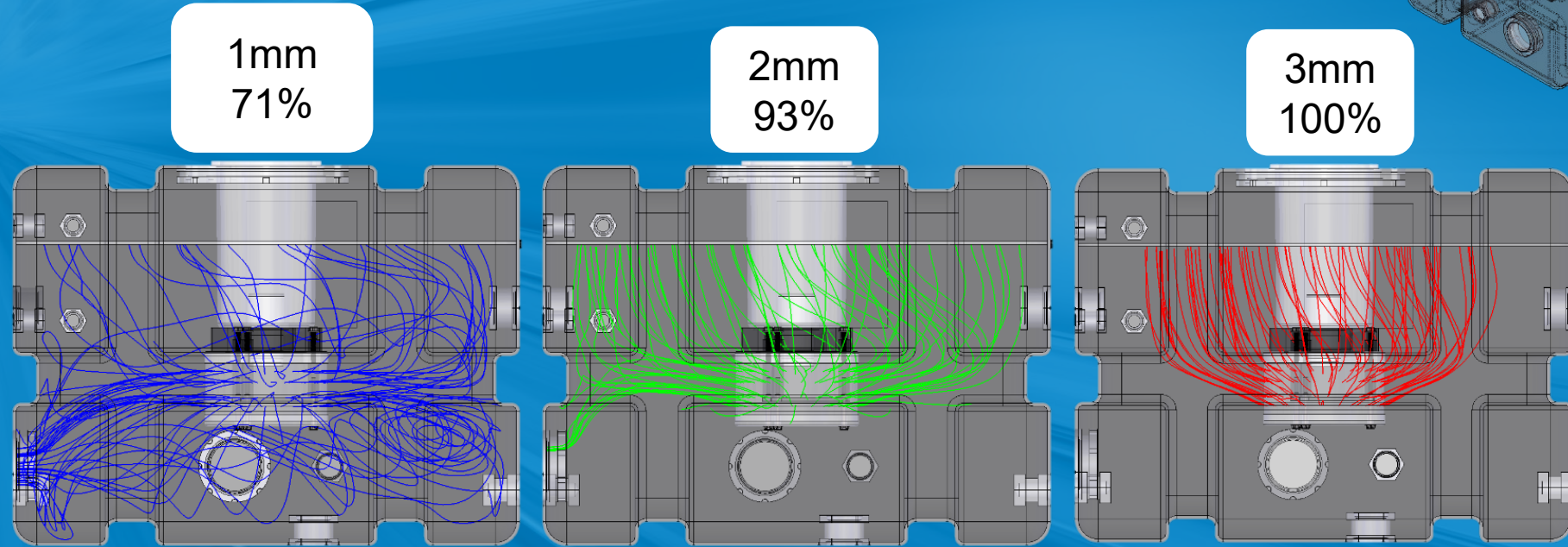

1, 2 and 3 mm air bubbles injected

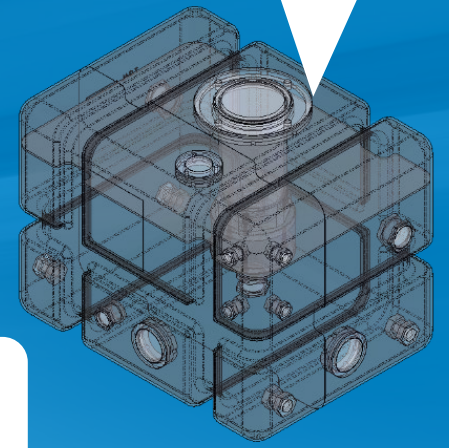

Multiple Sizes to fit in a wide array of applications

19.69 in.



14.81 in.

TNK7

Complete hydraulic tank solution (7 gal.) with included accessories.

Options

Filter, breather, sight glass, strainer, & band strap options

Desc.	Unit
Vol.	7 gal.
Filter	MTB
Flow	35 gpm
Weight	16 lbs.

Element Clearance
5" (127 mm)

19.69 in.



21.48 in.

TNK12

Complete hydraulic tank solution (12 gal.) with included accessories.

Options

Filter, breather, sight glass, strainer, & band strap options

Desc.	Unit
Vol.	12 gal.
Filter	ZT/GZT
Flow	40 gpm
Weight	21 lbs.

Element Clearance
10" (254 mm)

19.69 in.



21.47 in.

TNK18

Complete hydraulic tank solution (18 gal.) with included accessories.

Options

Filter, breather, sight glass, strainer, & band strap options

Desc.	Unit
Vol.	18 gal.
Filter	ZT/GZT
Flow	40 gpm
Weight	33 lbs.

Element Clearance
10" (254 mm)

27.38 in.



24.74 in.

TNK25

Complete hydraulic tank solution (25 gal.) with included accessories.

Options

Filter, breather, sight glass, strainer, & band strap options

Desc.	Unit
Vol.	25 gal.
Filter	RT/GRT
Flow	75 gpm
Weight	45 lbs.

Element Clearance
12" (305 mm)

Multitude of Mounting Options for Flexible Installation



Vertical Overhead

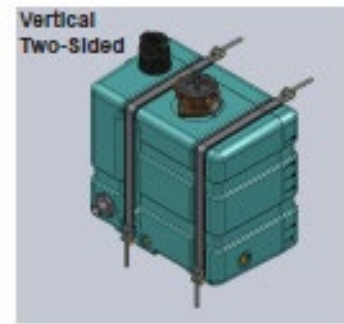

Vertical Two-Sided



Horizontal

Mounting Possibility Represents 12, 18 & 25 Gallon Strap Locations

TNK7 Straps*			
Vertical Overhead	444066	Horizontal Upper	444184

TNK12 Straps*			
Vertical Overhead	443868	Horizontal Upper	444066
Vertical Two-Sided	443889	Horizontal Lower	444185

TNK18 Straps*			
Vertical Overhead	3054998	Horizontal Upper	444490
Vertical Two-Sided	444183	Horizontal Lower	3521866

TNK25 Straps*			
Vertical Overhead	4231789	Horizontal Upper	444490
Vertical Two-Sided	444183	Horizontal Lower	4389641

*Straps are not sold in sets. Each part number designates one strap.



Schroeder supplies Custom Roto-molded Reservoir Solutions

- Tank
- Filter
- Breather
- Level gauge
- Strainer
- Clamps

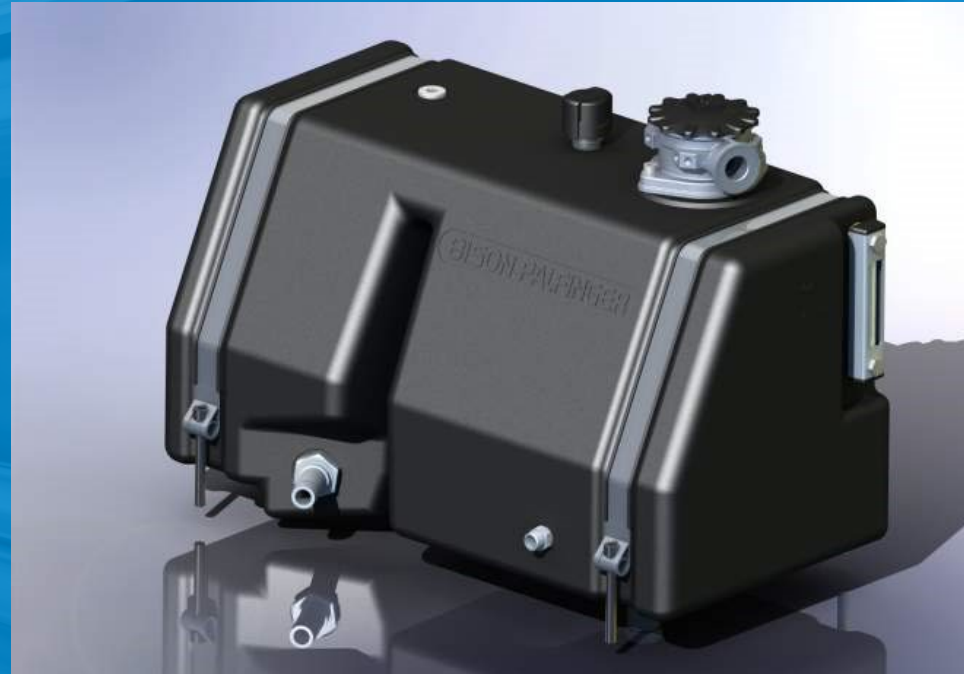

Schroeder
INDUSTRIES



Integration of Cooler into the reservoir envelope.

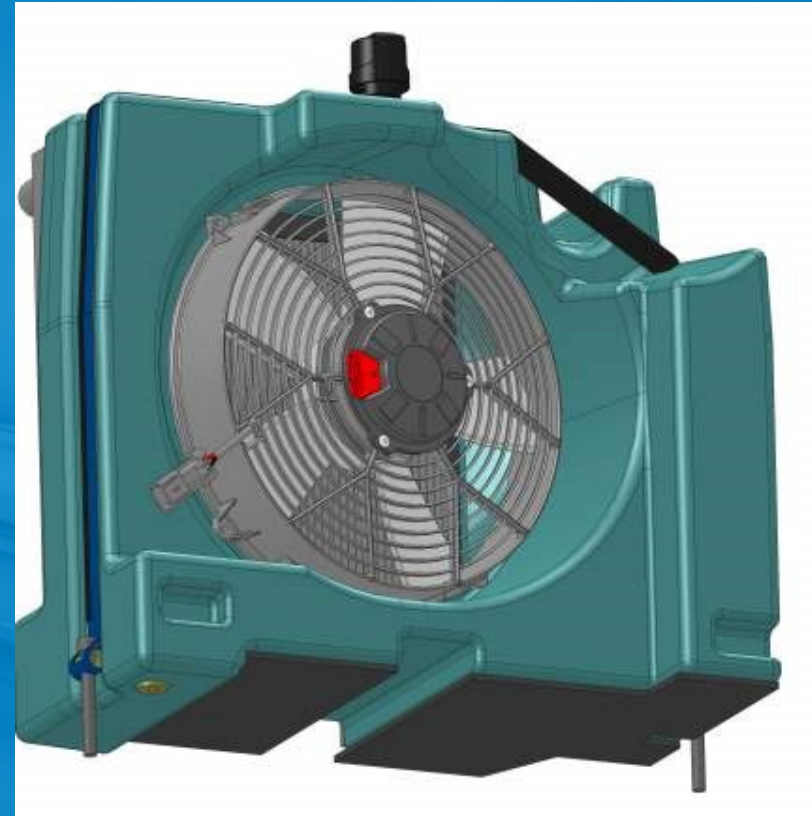

Interested to learn more?

- Select 1-5 items pertaining to the topic you are interested
- Click the “Request Information” button located directly under the product photo
- Mention “Fast Fifteen” in the comments section and a representative will be in touch

